

SYSTEMA

HEATING COOLING GREEN ENERGY

F80ECO

Air heating for animals, greenhouses and the like



**FAST AND EASY
INSTALLATION**

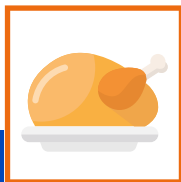

**HIGH MEAT
YIELD**



**EASY
INTEGRATION**



**LOW
MAINTENANCE**

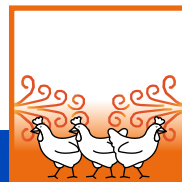

**HIGH AND RAPID
THERMAL COMFORT**



**LOW RUNNING
COSTS**

F80ECO HOT AIR GENERATOR

The **F80ECO** is a heating solution specially designed for poultry farms oriented towards breeds with a highly developed meat yield. In addition to the weaning phase (chick-rearing), these breeds also require more heat and air exchange in the later phases. In the winter period, given the typical weather conditions of the season such as humidity and cold, it is necessary to heat the herd adequately and diversified according to the growth phases of the animals.

F80ECO allows for increased animal welfare, improved meat yield and energy savings; noticeable after just the first week of use.

F80ECO is therefore the solution that is an excellent substitute for traditional systems such as irradiation lamps, which have a high energy consumption and are non-standard.

F80ECO IMMITS WARM AIR INTO THE ENVIRONMENT WITH 100% combustion yield and offers a considerable improvement in environmental conditions by limiting humidity, keeping bedding drier and increasing real well-being for the animal.

Extensive tests, compared with other heating solutions, have resulted in a saving of 23% on the energy consumed for heating, an increase in animal performance, with better quality feedback at the slaughterhouse.

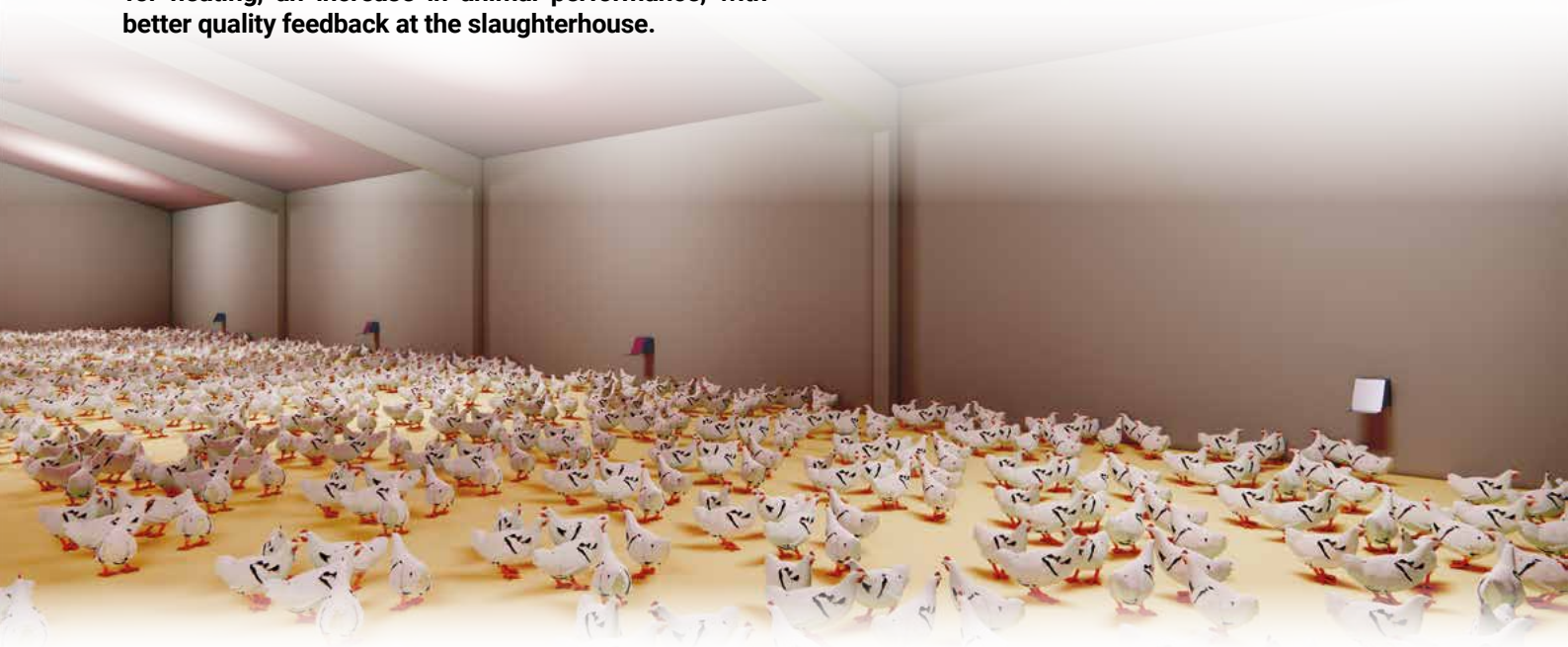

ADVANTAGES

- High efficiency
- Very low consumption
- Easy and fast installation
- Modular installation with several generators
- No chimney costs
- Maximum safety thanks to external installation

ADVANTAGES

- Rapid start-up and room heating in a short time
- Management of machine operation, temperature, alarms, can be integrated with existing control systems on the farm
- Low maintenance.
- 5 year warranty

GENERAL FEATURES F80ECO

The **F80ECO** has an all-weather steel panelled casing, and the generator is designed to be installed outside the room to be heated.

Installation of the heater is quick, is done using simple dowels, and can be installed either vertically or horizontally.

The **F80ECO** is equipped with an anti-intrusion protection grille located on the external air intake duct, and is complete with a duct for the diffusion of hot air inside the room.

Absence of thermal inertia in that the air injected into the room is immediately hot just a few seconds after being switched on.

100% thermal efficiency and no flue gas exhaust system.

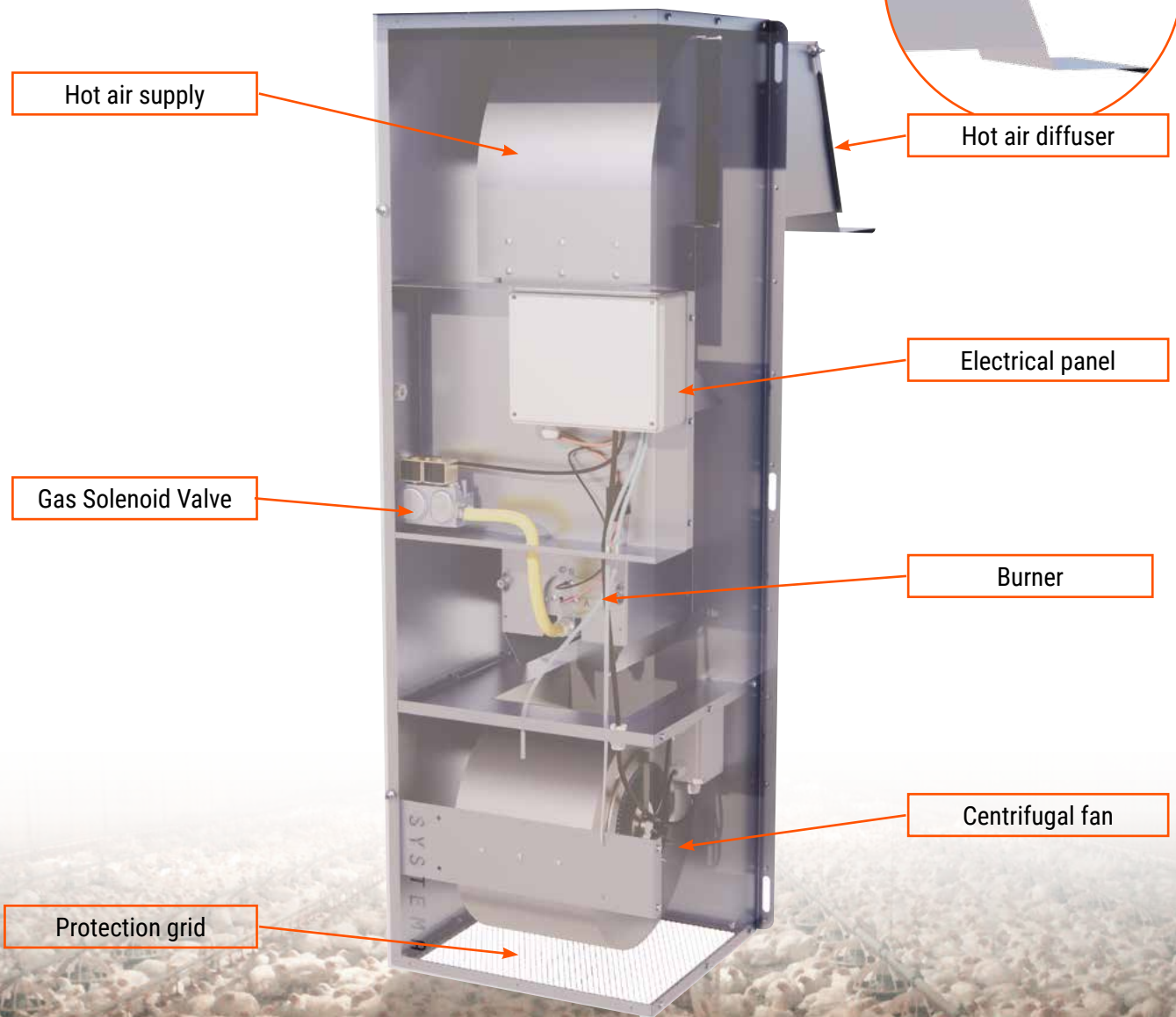
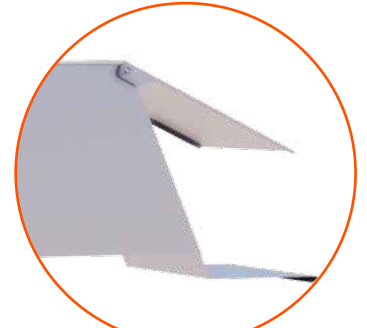

RANGE

Model	Use	Power
F80ECO	Breeding	72 kW

DIMENSIONS

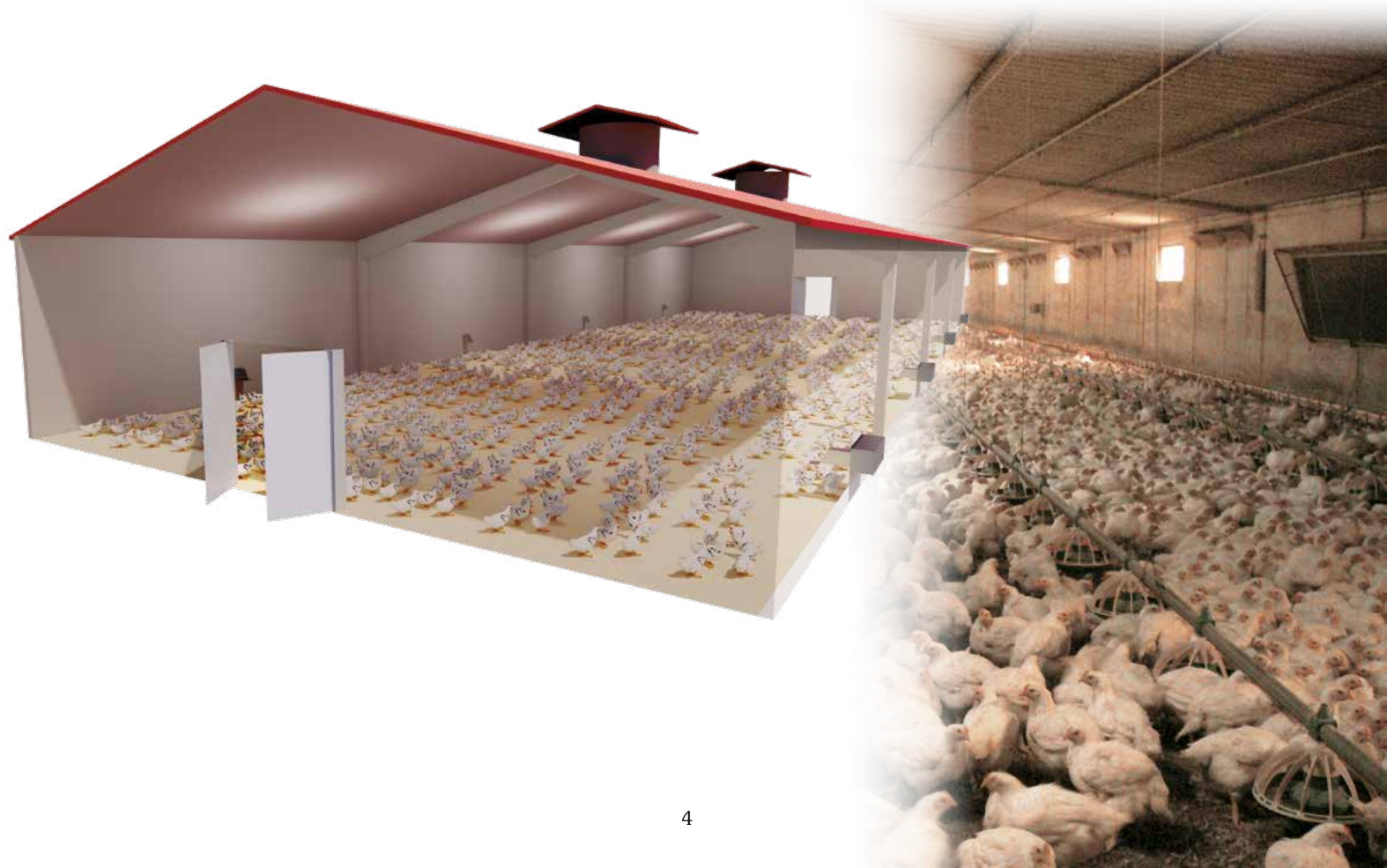
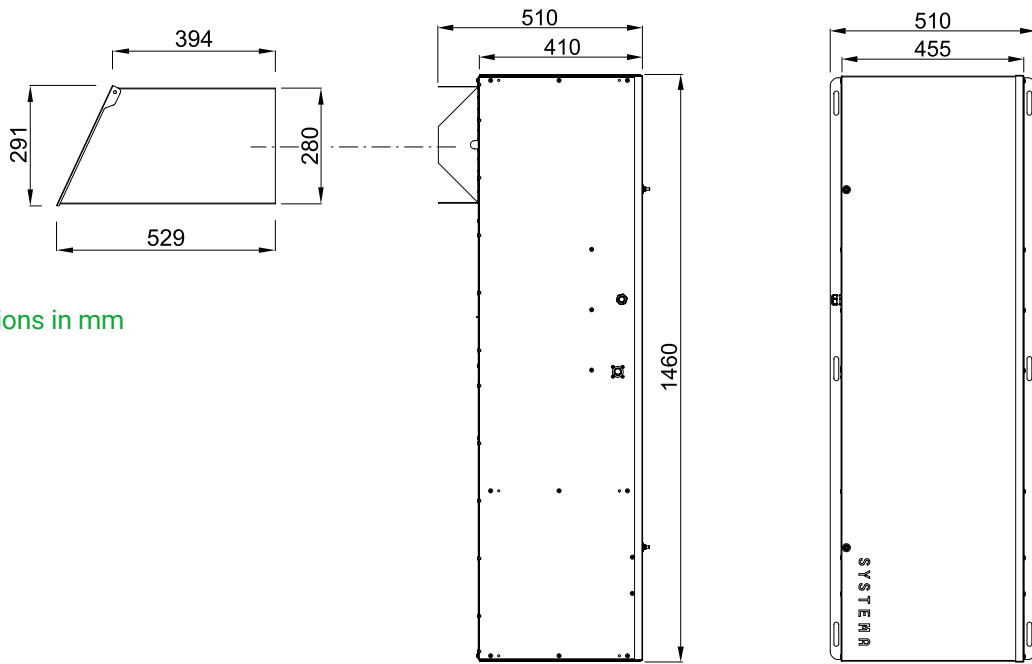

REFERENCES



EXPORT

Systema S.p.A. has exported, and continues to export its products and working methodology, in international contexts, always complying with the regulations of the country in which it operates.



For international development and for the integration of the offer, the decision to favour the establishment and development of the subsidiary Systema Polska in Poland was strategic; an organisation that, through highly modern and qualified production processes and a commercial structure in synergy with that of Systema S.p.A., has been able to establish itself over time and today is able to cover the needs of Poland and neighbouring countries in favour of the Group.



Production site in Poland

The synergies put in place have facilitated the growth of the services offered to the market, services made up of a very high level of attention to the customer who, in Systema, finds not only a business partner but a highly qualified technical consultancy service that goes hand in hand with reliable after-sales services that are always ready to quickly resolve any problems reported by the customers themselves.

 **Production site in Padua**





Since 1986, Systema S.p.A. is one of the leader companies in Italy and Europe in designing, developing and producing devices for the heating and conditioning in industrial and commercial buildings.

There has been always in Systema's Research and Development department where high investments have been made, since the beginning, for the creation of an internal laboratory who could design and offer highly innovative products that can satisfy and anticipate all the requests coming from the market. In this field Systema works together with important Italian, European and extra-European laboratories and university departments. A cooperation which leads to the concept of innovative and visionary products and solutions and to the obtaining of several international patents.

Systema S.p.A. differs from competitors because can offer a complete range of products that goes from commercial and industrial heating with radiant and hot air solutions, to conditioning with absorption chillers, electric heat pumps and evaporative adiabatic coolers and with a specific focus on the agricultural and breeding farms products for heating (both heaters and radiant systems) and conditioning with adiabatic coolers. This range has been conceived looking for environmental-friendly products with the lowest energy consumption.

Managing such a large range of products is not easy but, also in this field, Systema S.p.A. has been always different with an internal and external organization that guarantees high quality services through an extensive commercial network made of highly qualified technical salesmen, an internal organization of customer service with experience in designing and consultancies well aware of all the required standards and rules and a massive after sales structure both internal and external that Systema keeps regularly update in order to have technicians who are always very well prepared.

The work of these structures is greatly facilitated by Systema S.p.A.'s production facilities, which are made up of the highest quality standards and production processes that are technologically advanced and constantly modernised. The united work of those responsible for production, procurement and quality allows Systema S.p.A. to make available to its commercial structure products and systems that are of high quality, reliable and made in full compliance with the most advanced standards.

Systema S.p.A. is able to supply its sales organisation with products and systems of high quality and reliability and manufactured in full compliance with the most advanced standards.

Systema S.p.A. has thus managed, over the years, to gain a strong international presence which sees it active in markets all over the world, carrying forward the flag of top quality Made in Italy and achieving leadership positions in many countries. A strategic decision was taken by Systema S.p.A. to create Systema Polska, which is able to provide a highly qualified, high quality production force and a commercial structure, in synergy with that of Systema S.p.A., which is able to present and improve the commercial penetration of Systema products in markets such as Poland and neighbouring countries.

The synergies put in place have greatly facilitated the growth of the services offered to the market, services made up of a very high level of attention to the customer, who in Systema finds not only a business partner but also a highly qualified technical consultancy service that goes hand in hand with reliable after-sales services that are always ready to quickly resolve any problems reported by the customers themselves.

*Systema: focus on the future
by interpreting the present...*



SYSTEMA S.p.A. Via San Martino, 17/23 - Santa Giustina in Colle C.A.P. 35010 PADOVA - ITALY

Tel. +39.049.9355663 r.a. - export@systema.it

www.systema.it